

DP 3069 MT 3~ 230

Кривая рабочей характеристики

Насос

Диаметр выхода	65 mm
Диаметр всасывающего фланца	163 mm
Impeller diameter	163 mm
Количество лопастей	6

Motor

Двигатель	D3069.180 13-10-2BB-W 2.4KW
Тип статора	7
Частота	50 Hz
Ном/напряжение	190 V
Число полюсов	2
Фазы	3~
Ном. мощность	2,4 kW
Номинальный ток	11 A
Пусковой ток	60 A
Ном. скорость вращения	2785 rpm

Коэффициент мощности	
1/1 Load	0,84
3/4 Load	0,78
1/2 Load	0,65
Motor efficiency	
1/1 Load	80,2 %
3/4 Load	82,8 %
1/2 Load	83,3 %

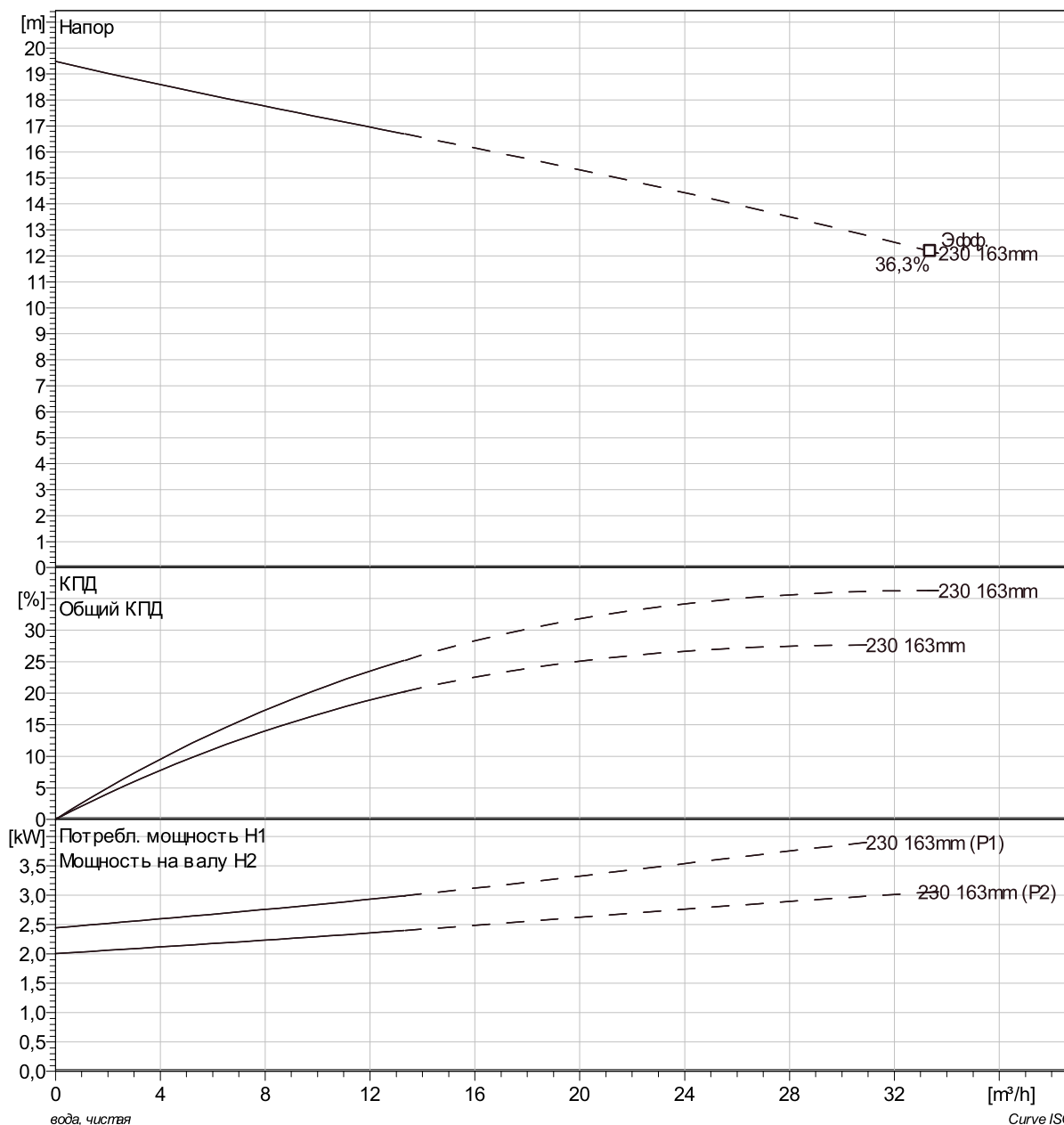

DP 3069 MT 3~ 230 Duty Analysis

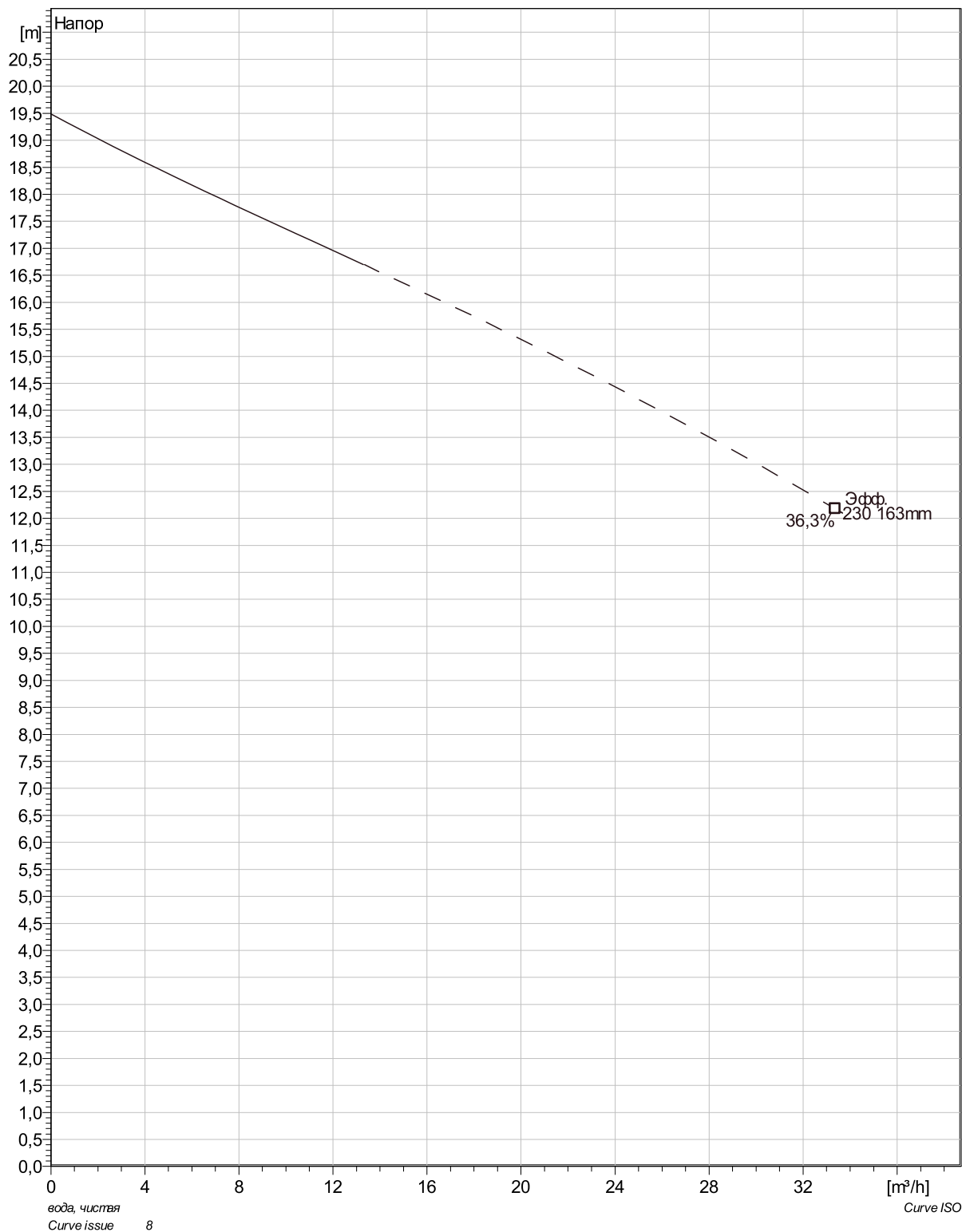

Project	Project ID	Created by	Created on	Last update
			4/2/2019	

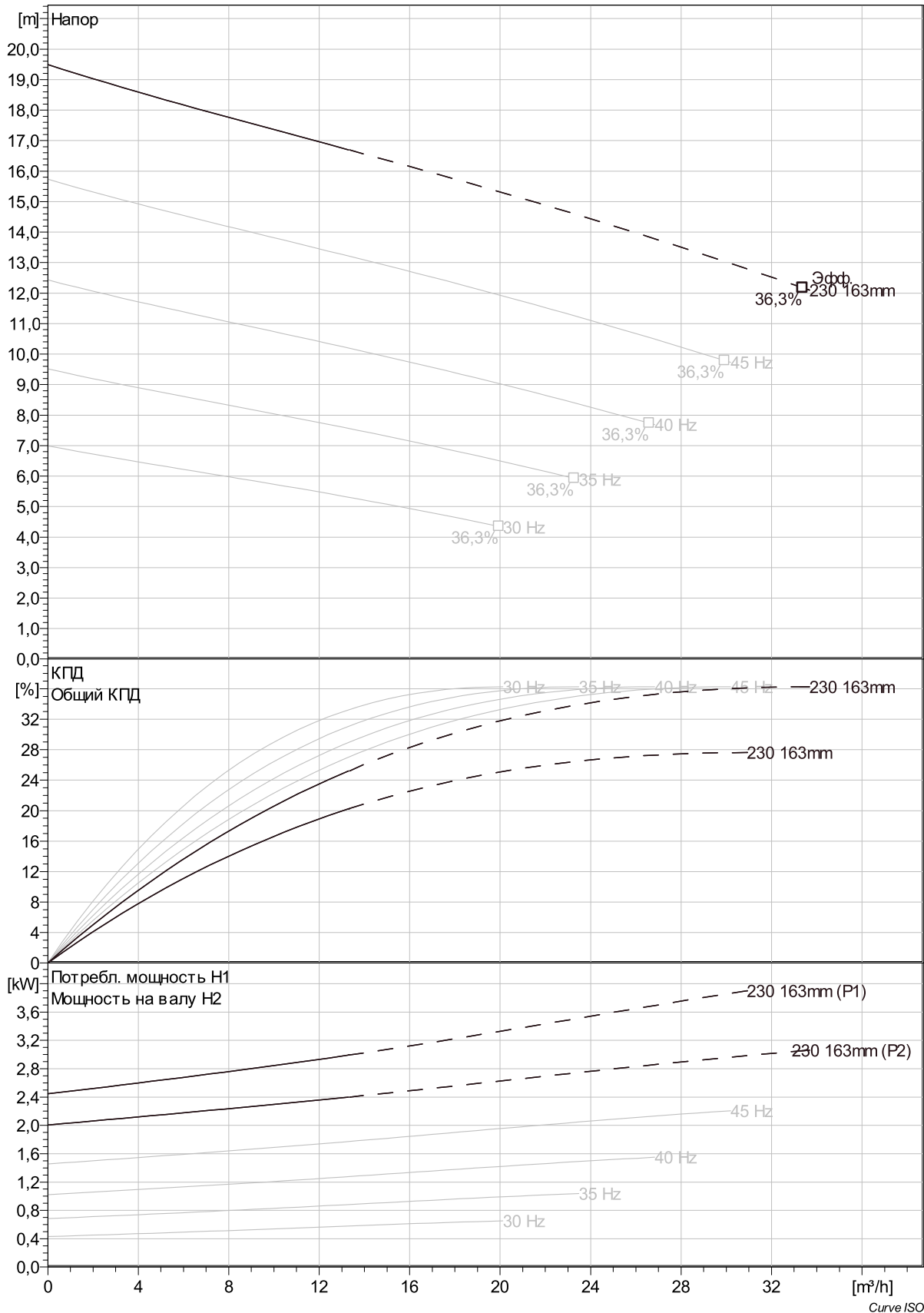

Project	Project ID	Created by	Created on	Last update
			4/2/2019	

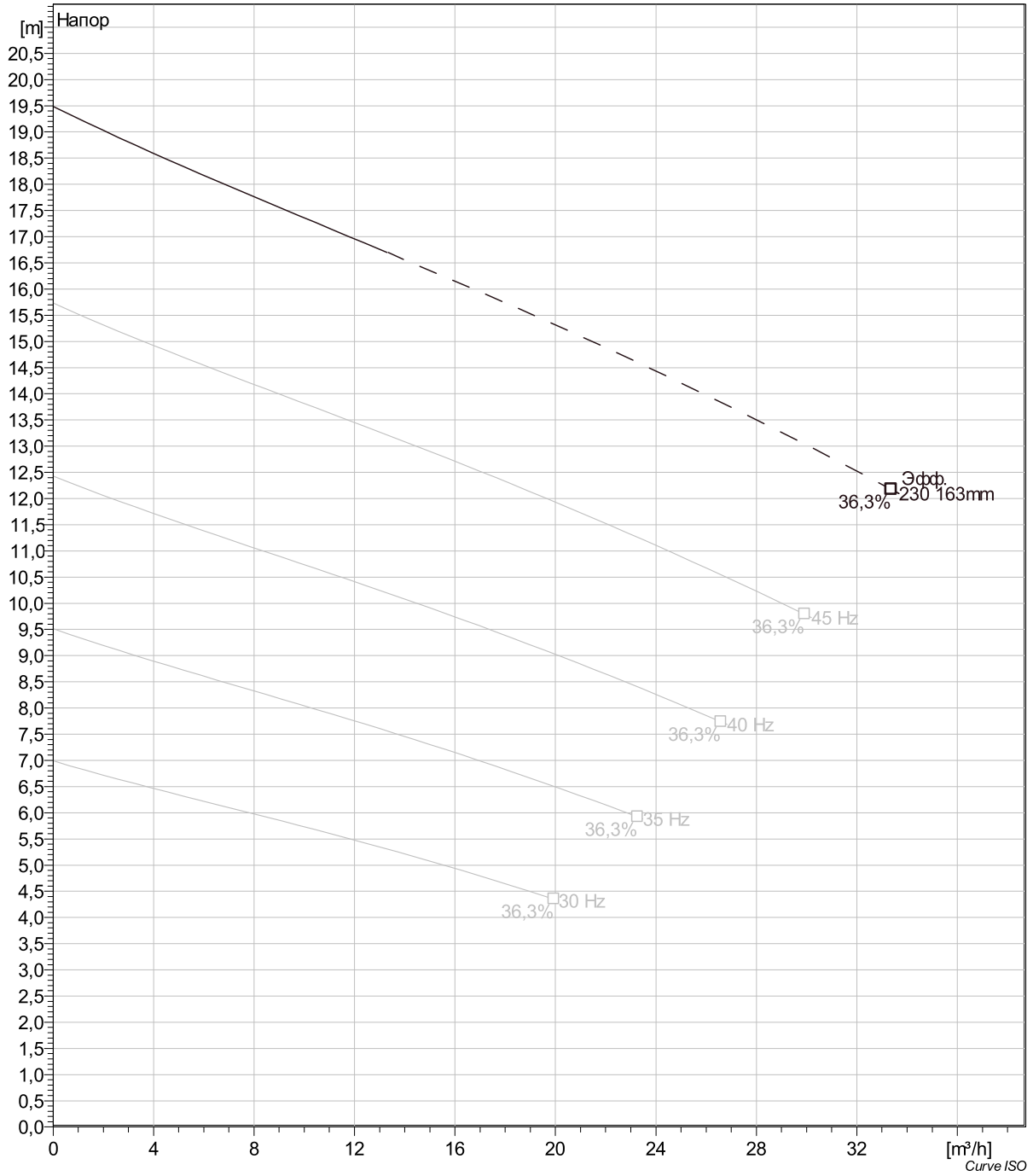

Project	Project ID	Created by	Created on	Last update
			4/2/2019	

DP 3069 MT 3~ 230 Dimensional drawing

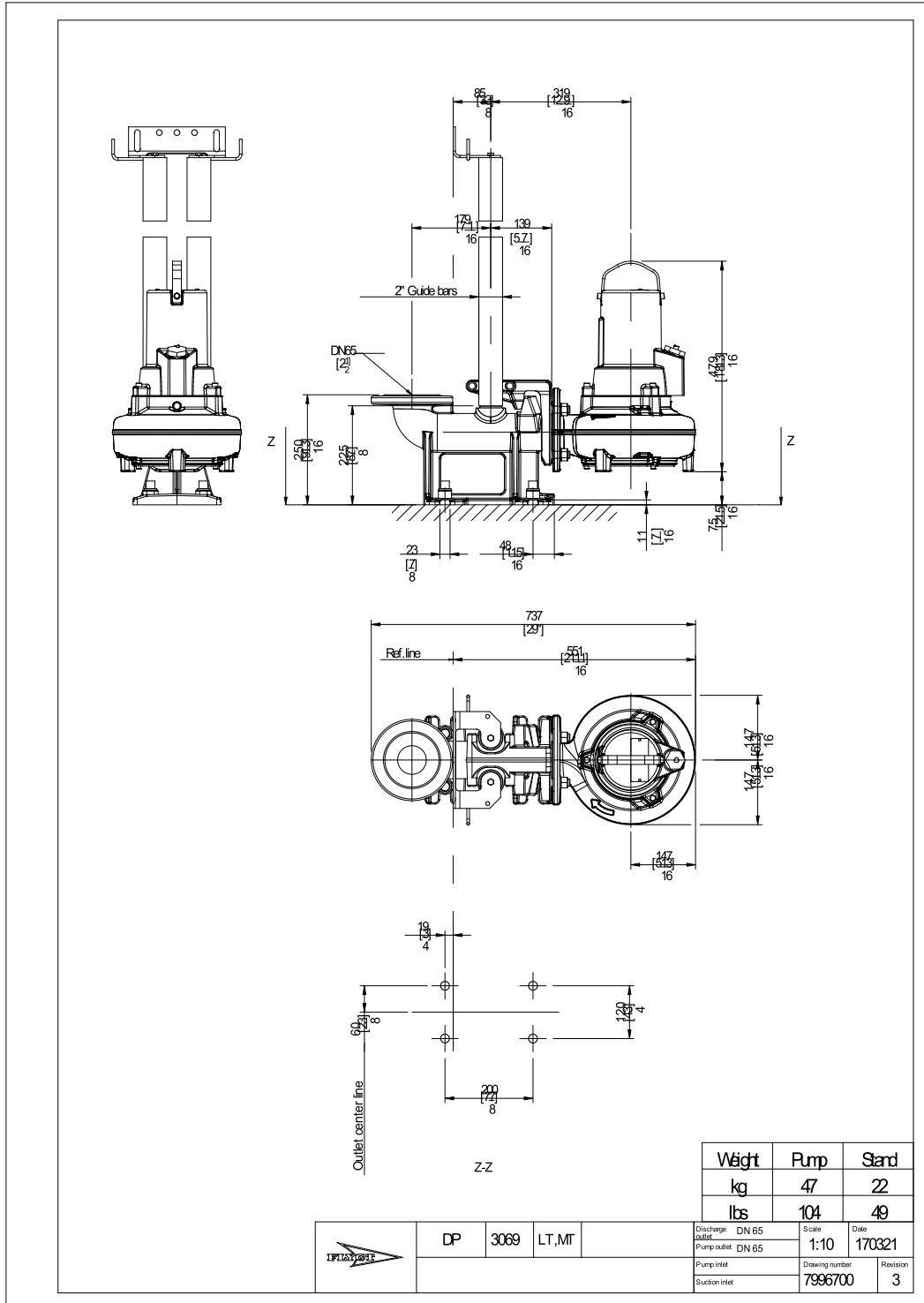

Project

Project ID

Created by

Created on
4/2/2019

Last update