

SECTION A-A

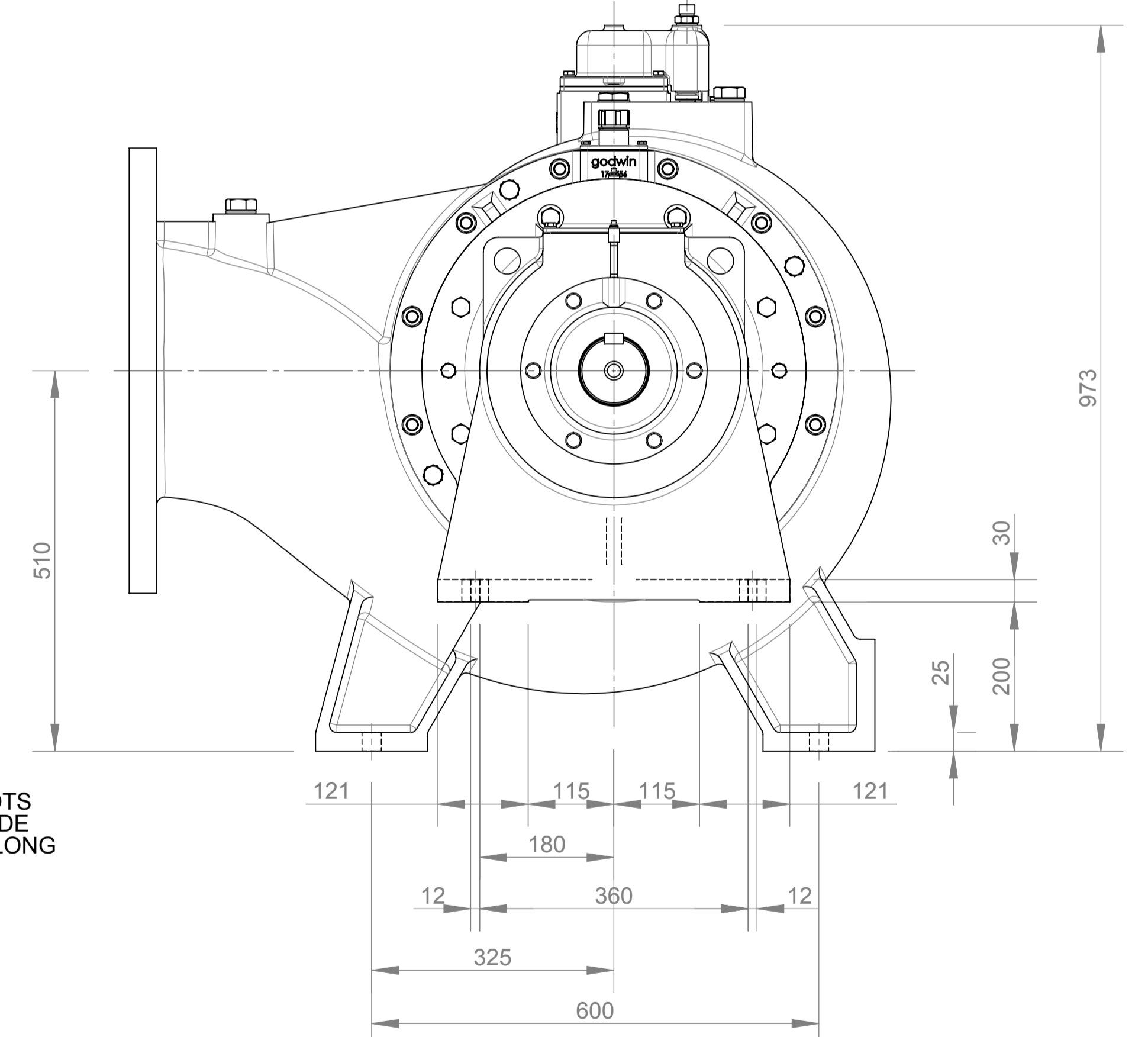
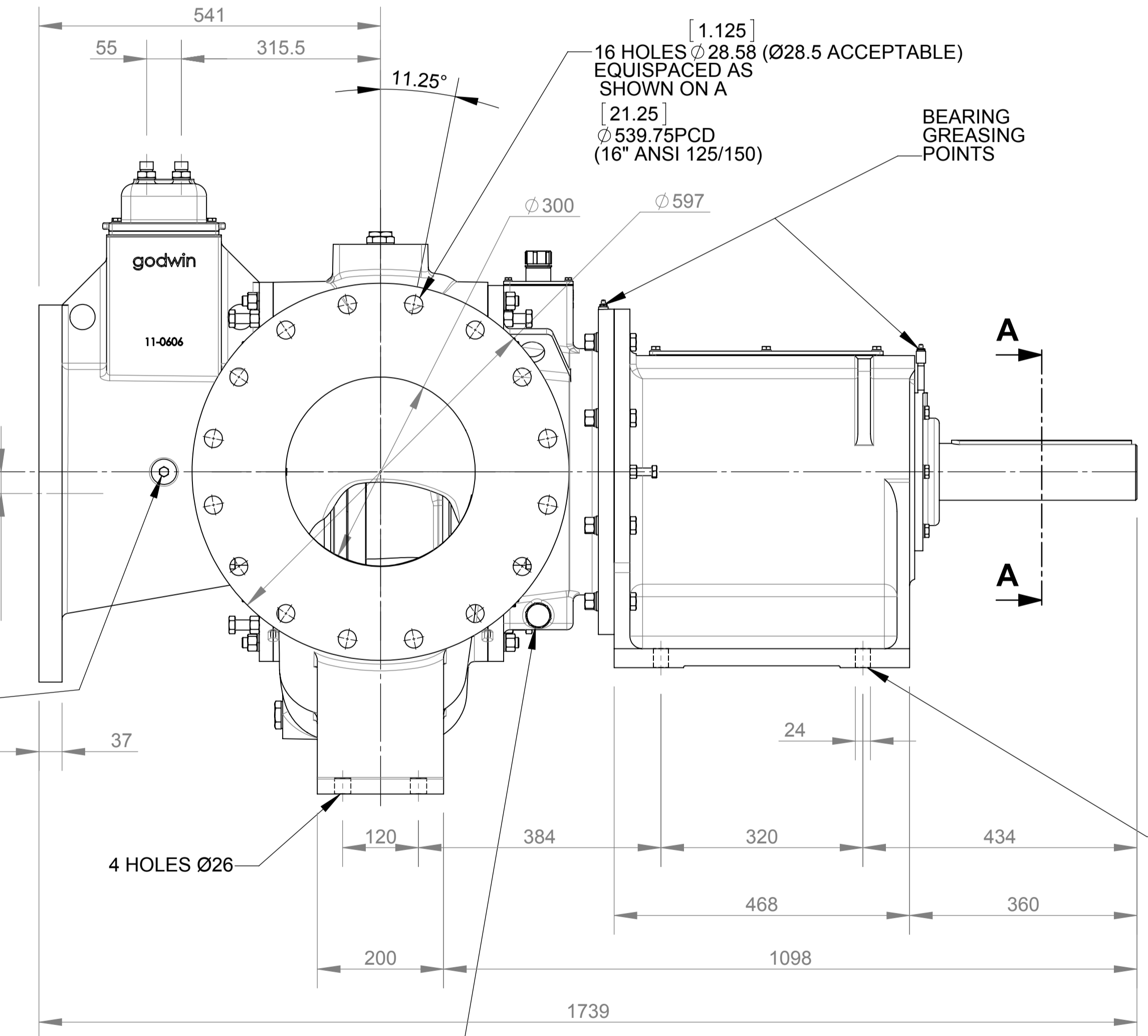
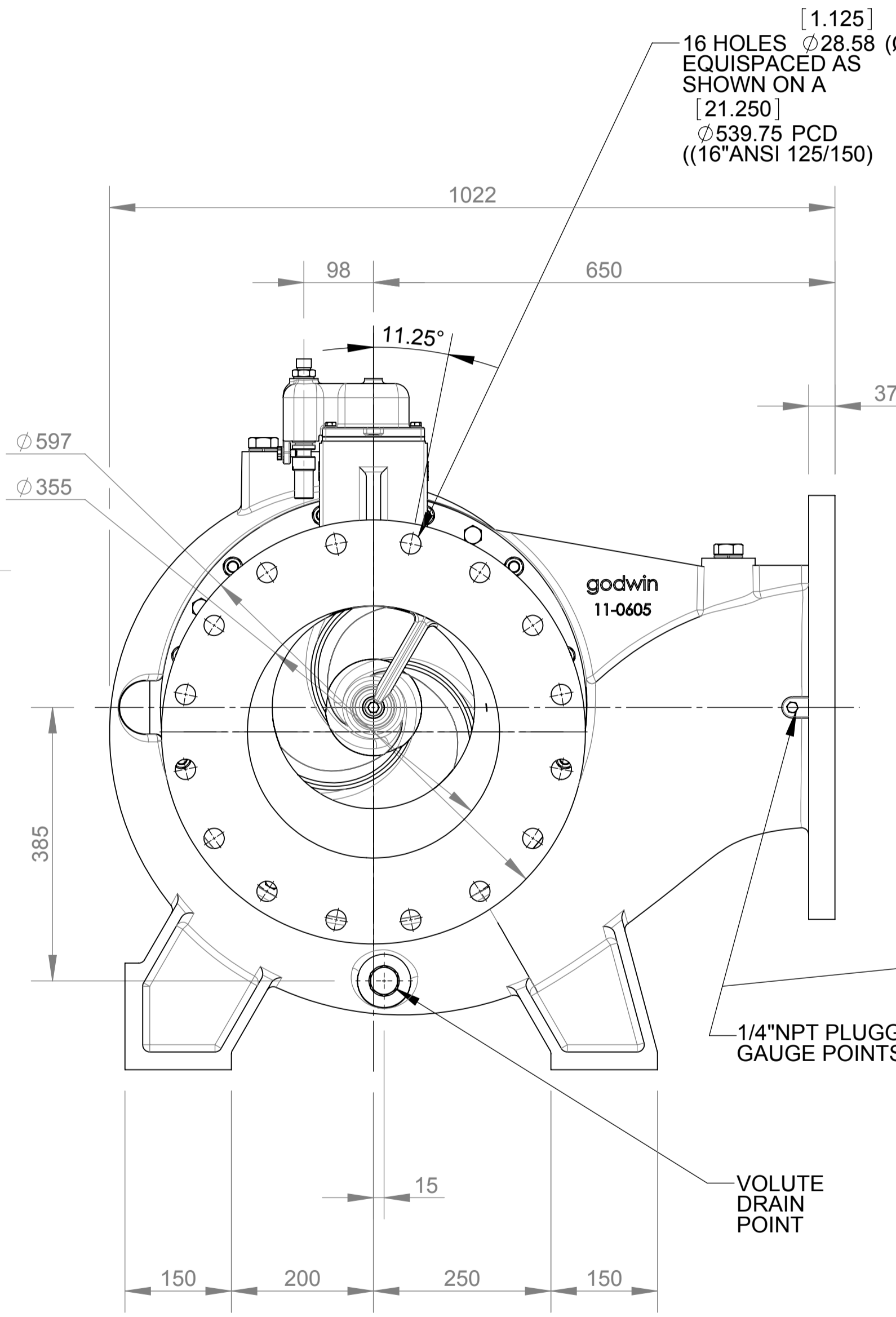

Xylem Dewatering Solutions  
Quenington, Cirencester  
Gloucestershire  
GL7 5BX, UK.

Tel: +44 (0)1285 750271  
Fax: +44 (0)1285 750352  
© 2012

UNLESS OTHERWISE SPECIFIED:  
Dimensions in millimetres  
Surface finish in microns  
TOLERANCES  
MACHINING above 500 ±0.75  
50 to 500 ±0.4  
0 to 50 ±0.25  
1 dec. pl. ±0.1  
Angular ±0°15'  
FABRICATION above 1000 ±5.0  
500 to 1000 ±3.0  
125 to 500 ±1.5  
0 to 125 ±0.75  
Angular ±0°30'  
FLATNESS above 1000 ±3.0  
250 to 1000 ±2.0  
0 to 250 ±1.0  
GA's & ASSEMBLIES above 1000 ±5  
up to 1000 ±3

TITLE: NC350 BARESHAFT DRI-PRIME  
C.I. CONST. FLG 16" X 16" ANSI 150

IF IN DOUBT - ASK  
DO NOT SCALE DRAWING  
THIRD ANGLE PROJECTION  
TPS TO BS 8888:2008

PART NO. NC350-BS-002

MATERIAL:  
DWG NO. NC350-BS-002

NAME	DATE
DRAWN AJ	10/03/2014
APP'VD	
RELEASED AJ	14/03/2014

WEIGHT: kgs SCALE: 1:6 SHEET 1 of 1

ISSUE	DESCRIPTION	ECO No.	BY	DATE
1	CN003975. Compiled.	ECO14-011	AJ	14/03/2014

ISSUE 1  
A1