

PP 4630 ** 3~ 837

Кривая рабочей характеристики

Насос

Диаметр выхода 375 mm
 Диаметр всасывающего фланца 368 mm
 Impeller diameter 368 mm
 Количество лопастей 3

Motor

Двигатель P4630.412 18-08-8AA-W 1.5KW
 Тип статора 25
 Частота 50 Hz
 Ном/напряжение 180 V
 Число полюсов 8
 Фазы 3~
 Ном. мощность 1,5 kW
 Номинальный ток 9,2 A
 Пусковой ток 30 A
 Ном. скорость вращения 710 rpm

Коэффициент мощности
 1/1 Load 0,71
 3/4 Load 0,62
 1/2 Load 0,50
 Motor efficiency
 1/1 Load 73,6 %
 3/4 Load 74,0 %
 1/2 Load 70,8 %

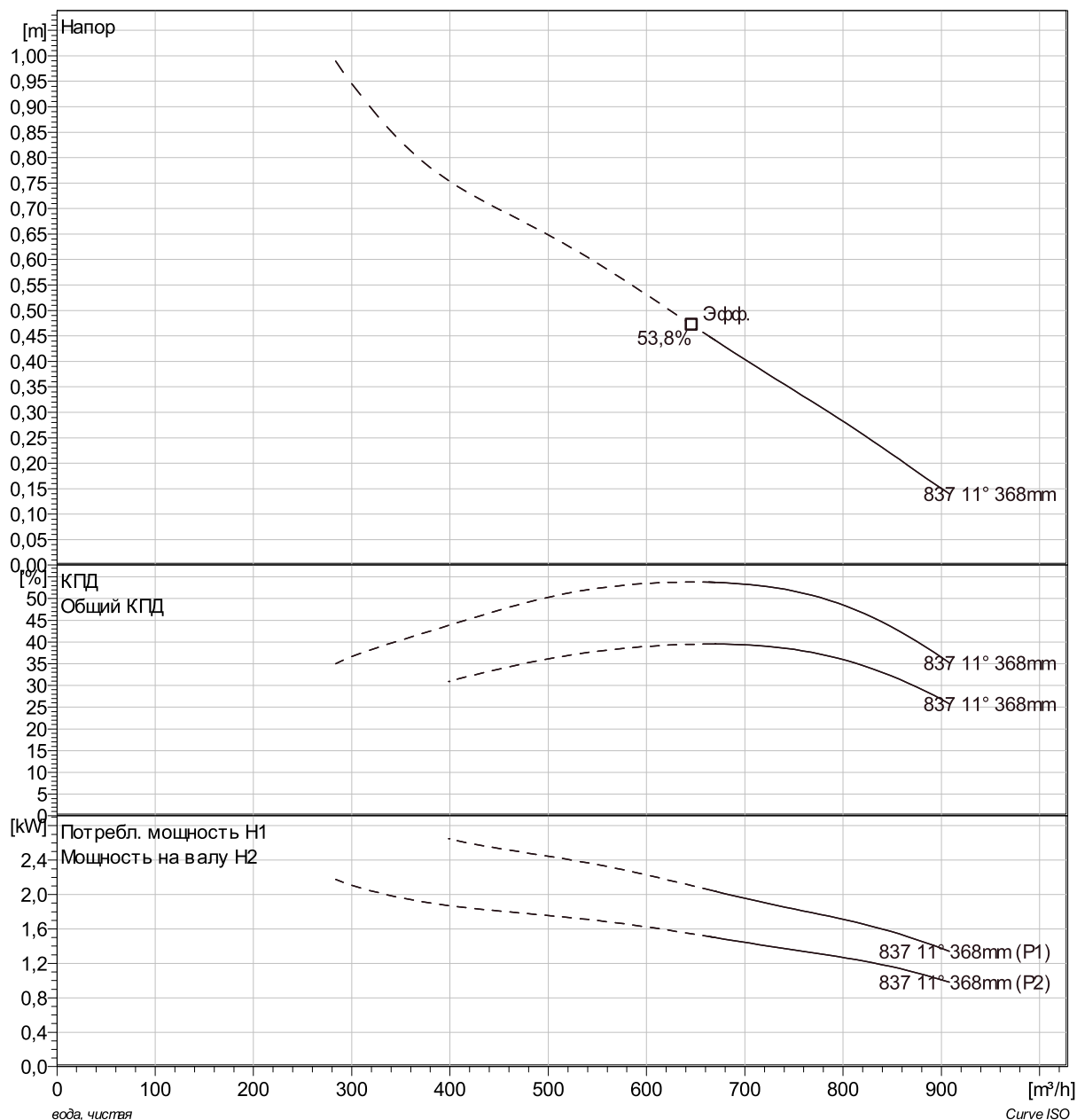

Project	Project ID	Created by	Created on 4/4/2019	Last update
---------	------------	------------	------------------------	-------------

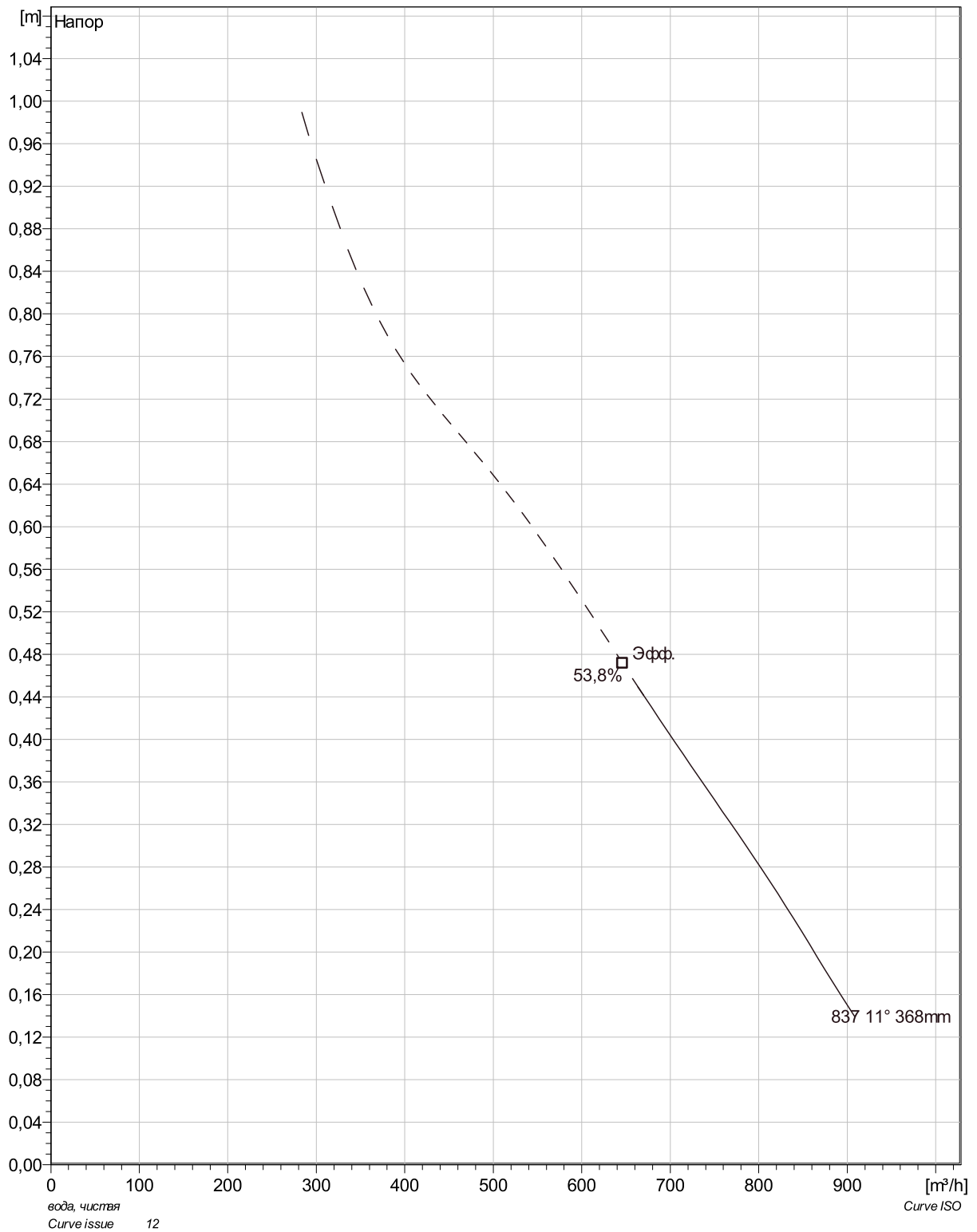

Project	Project ID	Created by	Created on	Last update
			4/4/2019	

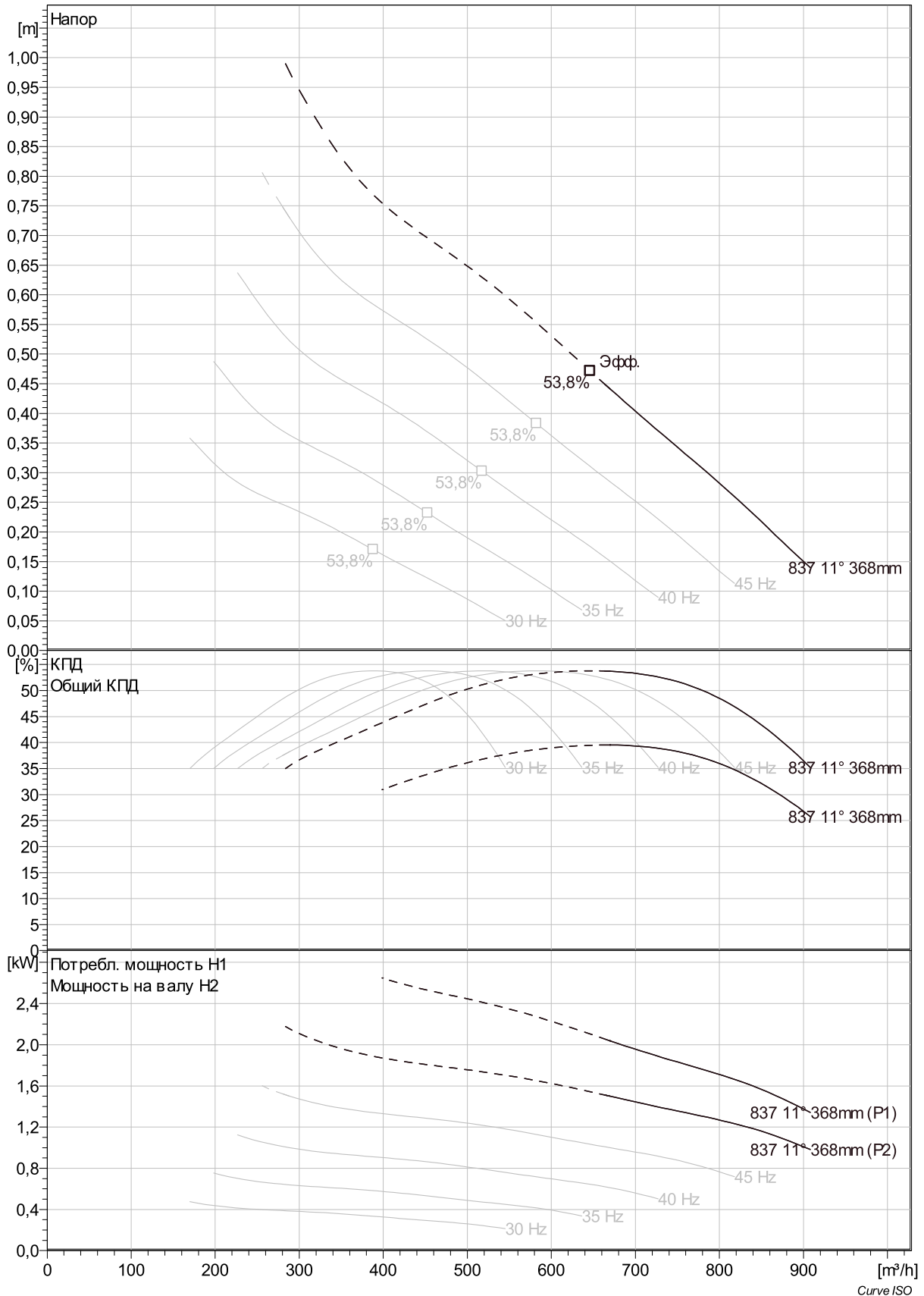

Project	Project ID	Created by	Created on	Last update
			4/4/2019	

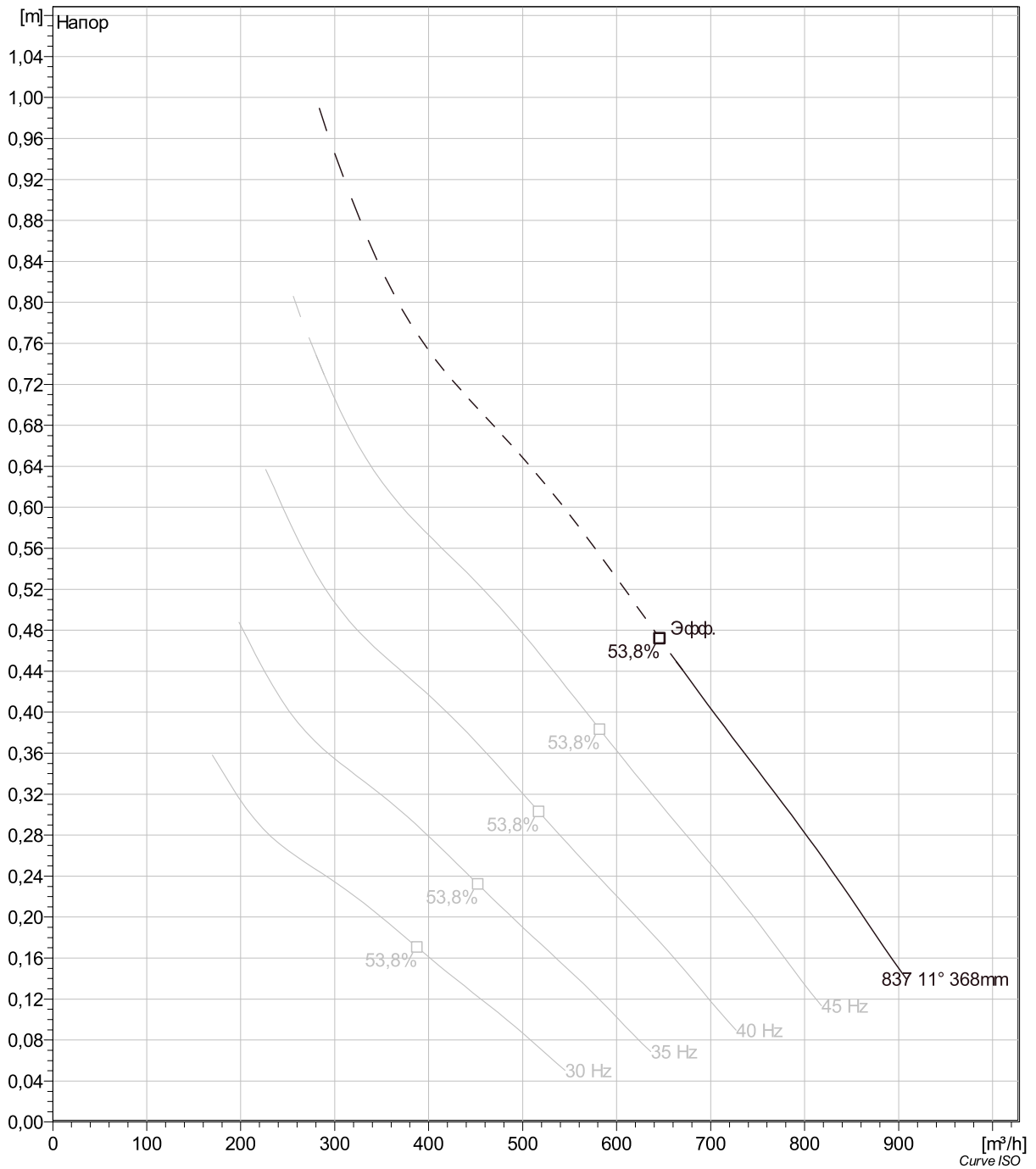

Project	Project ID	Created by	Created on	Last update
			4/4/2019	

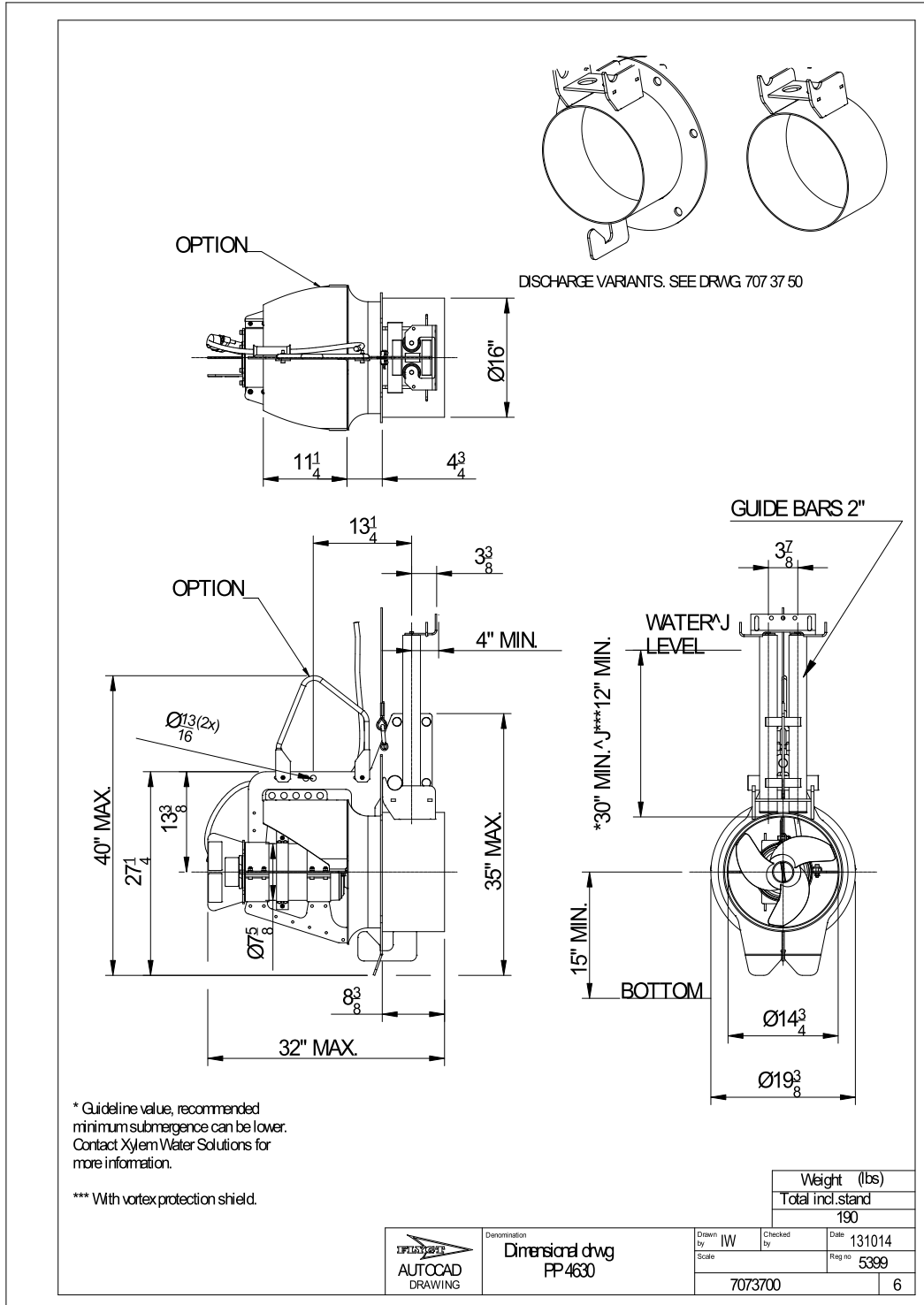

Project	Project ID	Created by	Created on 4/4/2019	Last update
---------	------------	------------	------------------------	-------------