

PL 7030 ** 3~ 440

Кривая рабочей характеристики

Насос

ColDia 500 mm
Диаметр всасывающего фланца 345 mm
Impeller diameter 345 mm
Количество лопастей 3

Motor

Двигатель P7030.180 30-29-4AA-W 50KW
Тип статора 1
Частота 50 Hz
Ном/напряжение 380 V
Число полюсов 4
Фазы 3~
Ном. мощность 50 kW
Номинальный ток 91 A
Пусковой ток 500 A
Ном. скорость вращения 1470 rpm

Коэффициент мощности
1/1 Load 0,92
3/4 Load 0,90
1/2 Load 0,85
Motor efficiency
1/1 Load 91,1 %
3/4 Load 92,5 %
1/2 Load 93,3 %

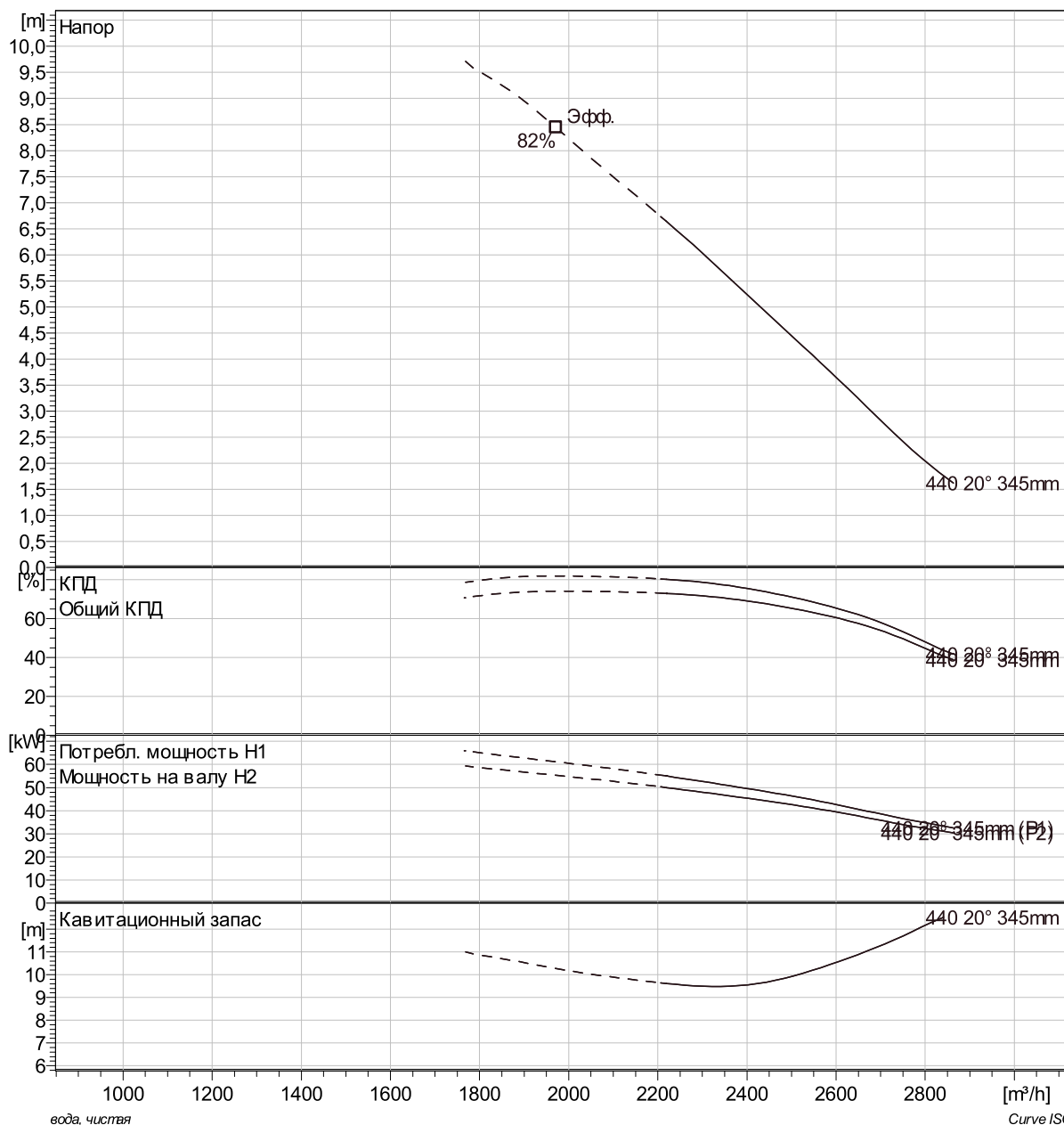

Project	Project ID	Created by	Created on 4/4/2019	Last update
---------	------------	------------	------------------------	-------------

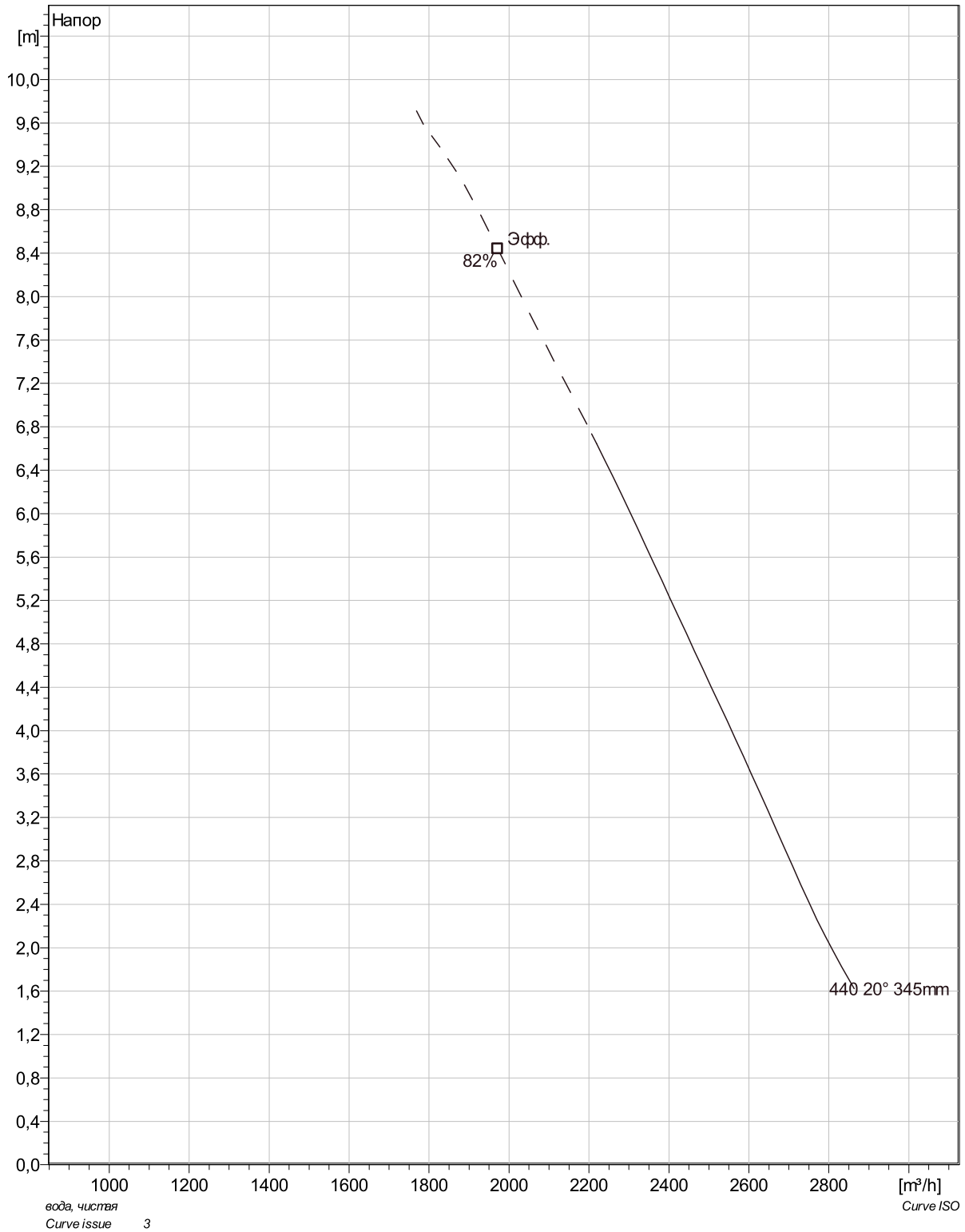

Project	Project ID	Created by	Created on	Last update
			4/4/2019	

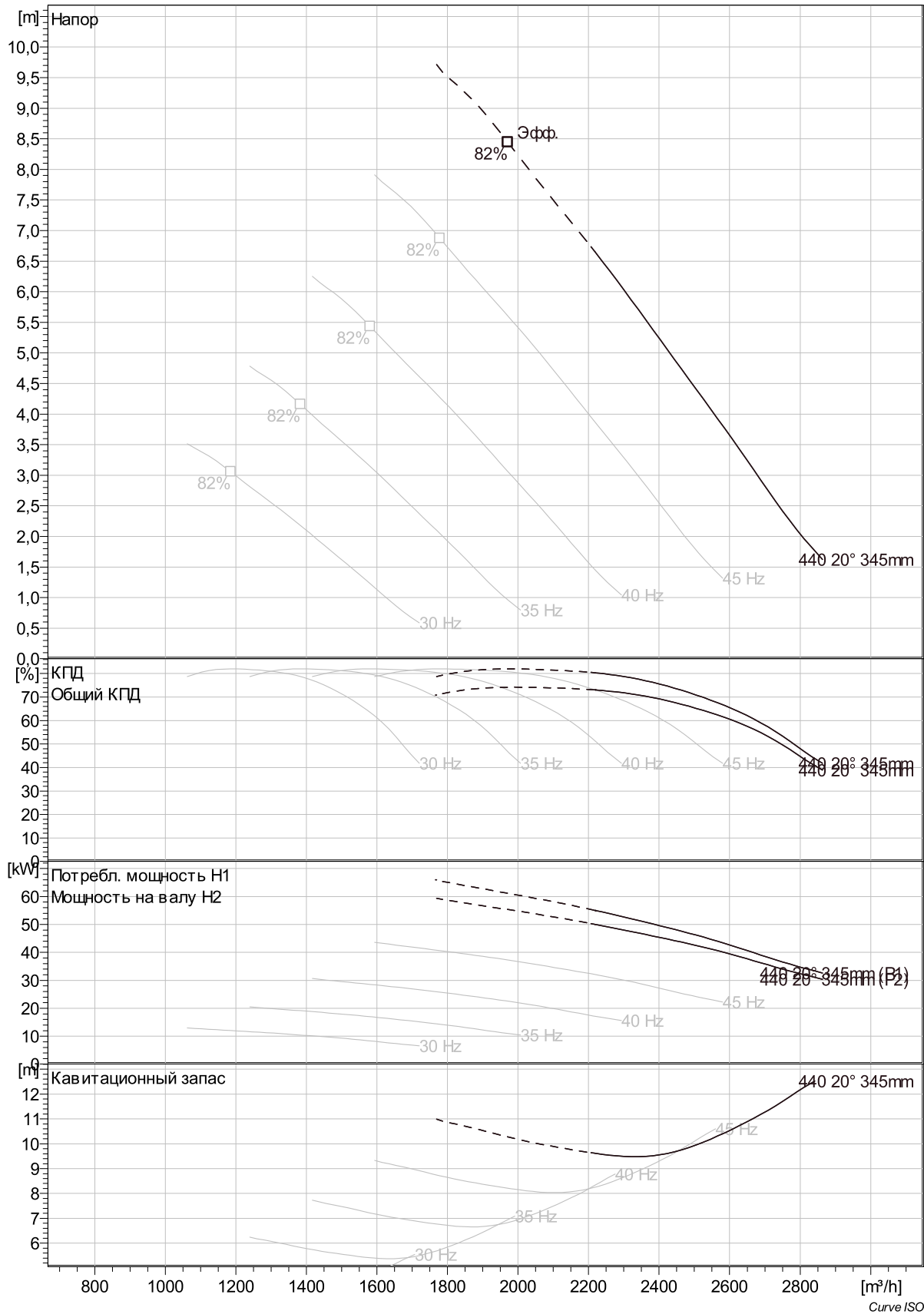

Project	Project ID	Created by	Created on	Last update
			4/4/2019	

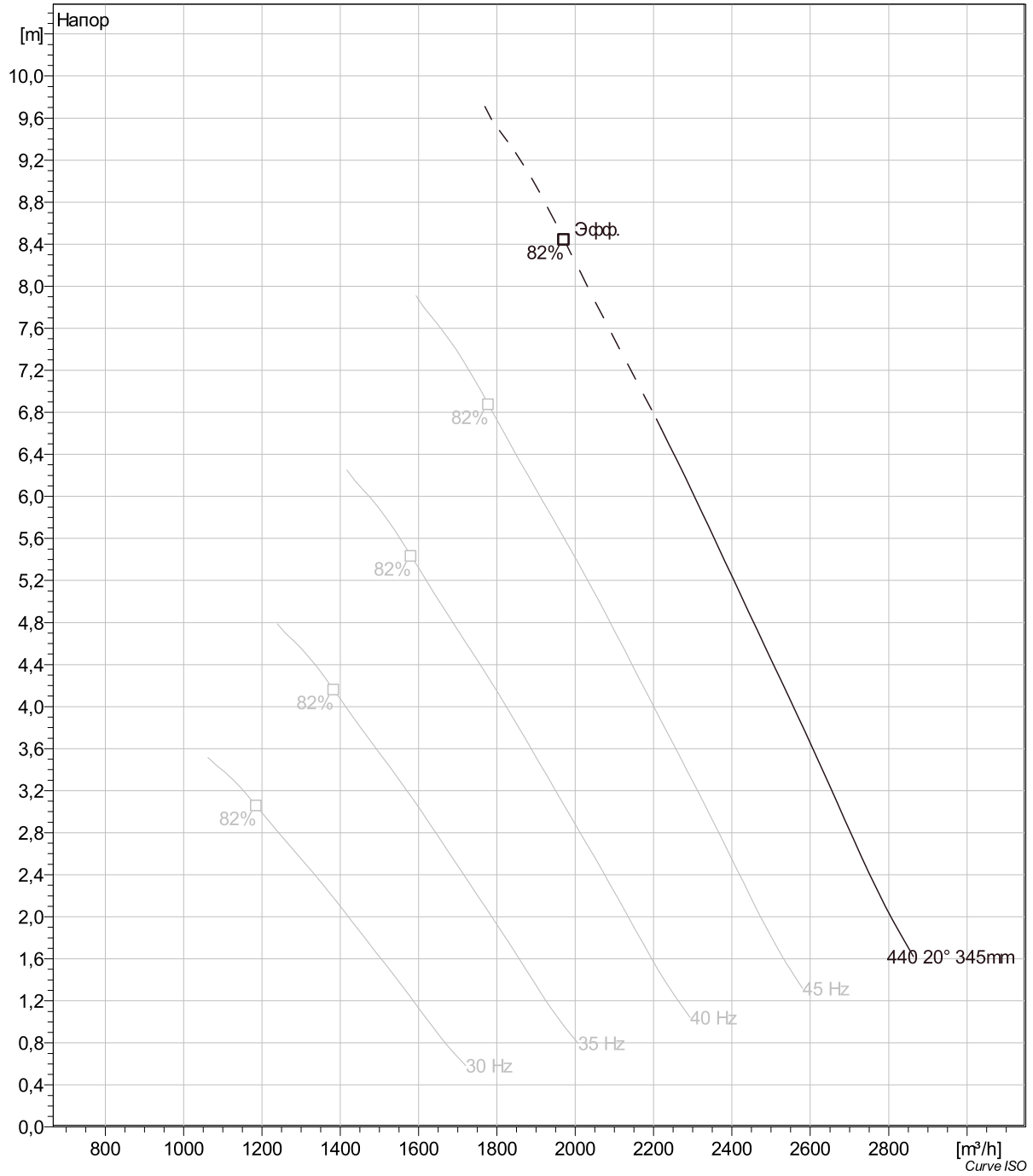

Project	Project ID	Created by	Created on	Last update
			4/4/2019	

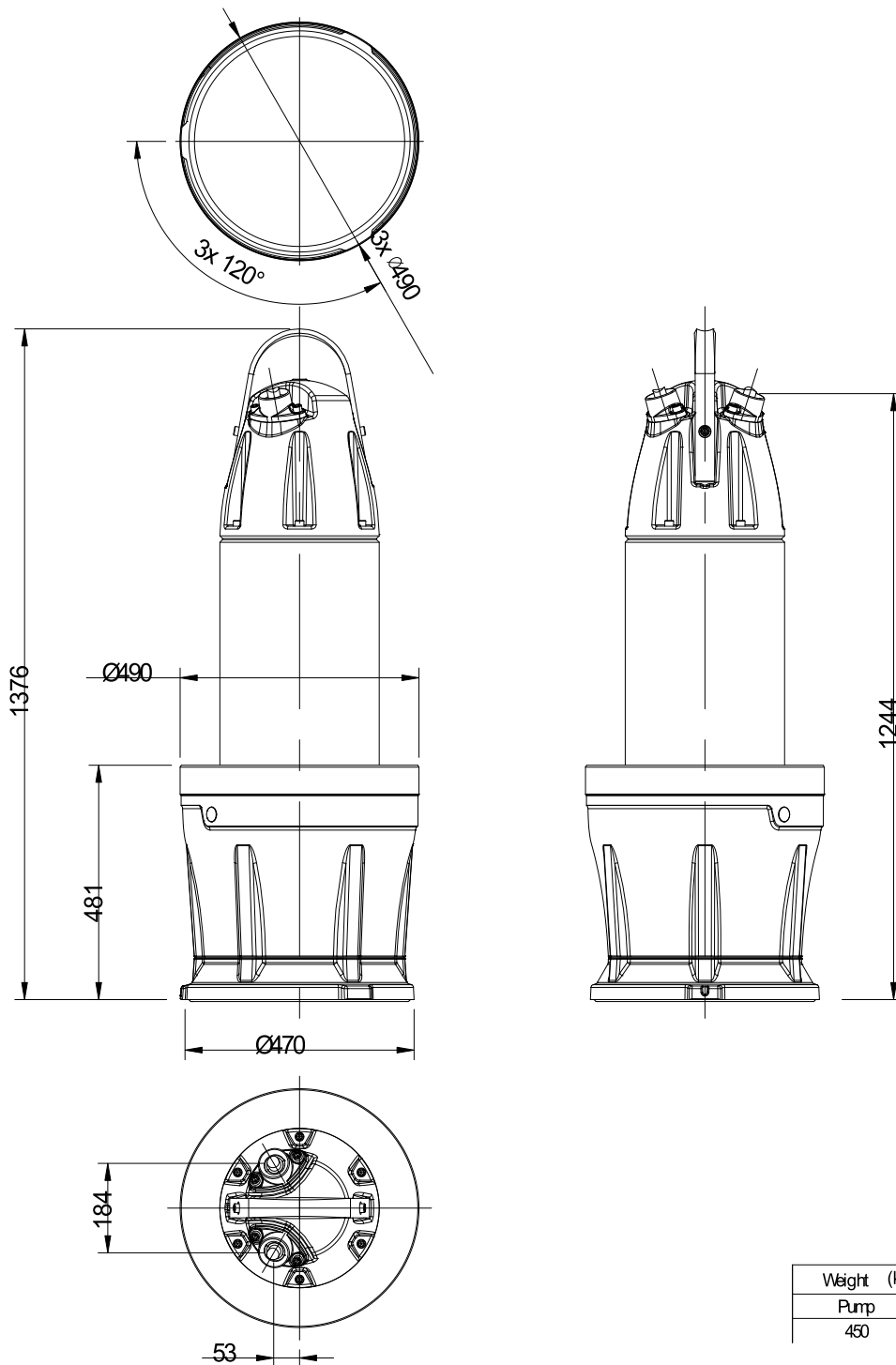

PL 7030.180

Project	Project ID	Created by	Created on 4/4/2019	Last update
---------	------------	------------	------------------------	-------------